

TECHNICAL INSTALLATION AND MAINTENANCE MANUAL

LPG PRESSURE REDUCER "SPECTRE"

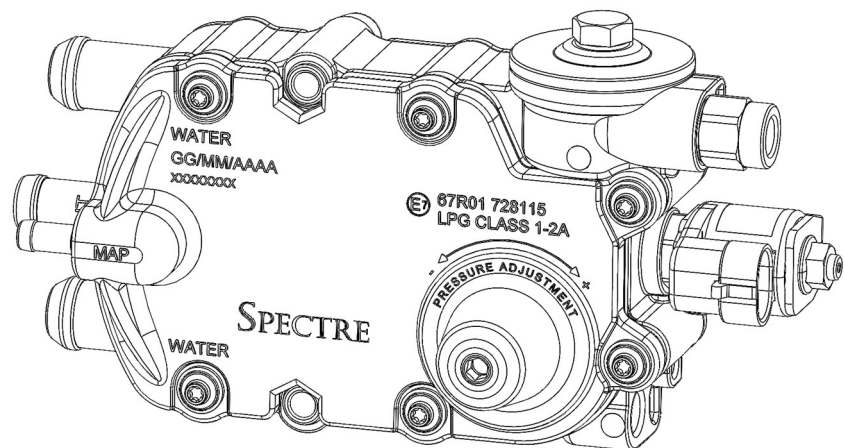

SUMMARY

LPG PRESSURE REDUCER "SPECTRE"	1
1. INTRODUCTION.....	3
2. OPERATING PRINCIPLE.....	3
3. TECHNICAL DATA	3
4. INSTALLATION GUIDELINES.....	5
4.1 GENERAL RECOMMENDATIONS.....	5
4.2 INSTALLATION PROCEDURE	6
5. MAINTENANCE.....	11
6. SAFETY WARNINGS.....	11
7. WARRANTY CONDITIONS.....	11
8. APPENDICES.....	12

Rev N.	Date	Description of the changes
00	10/07/2025	First emission
01	24/07/2025	Updated the ' <i>Connecting the Heating Lines</i> ' section
02	04/08/2025	Updated Annex B, C
03	18/11/2025	Updated images, annexes, guidelines
04	09/11/2025	Updated guidelines, Tightening torques
05	09/04/2026	Removed M5 temperature sensor seat as an optional (standard hole)

1. INTRODUCTION

This manual provides technical and safety information for the correct installation, usage, and maintenance of the LPG Spectre pressure reducer.

2. OPERATING PRINCIPLE

The SPECTRE reducer transforms LPG (Liquefied Petroleum Gas) from liquid to gaseous phase, reducing its pressure to a constant value suitable for engine injection. The regulator is a single stage compensated unit with a membrane with water/gas heat exchanger.

3. TECHNICAL DATA

For detailed technical information about Ecomotive Solutions products, please visit the company's website using the QR code below:



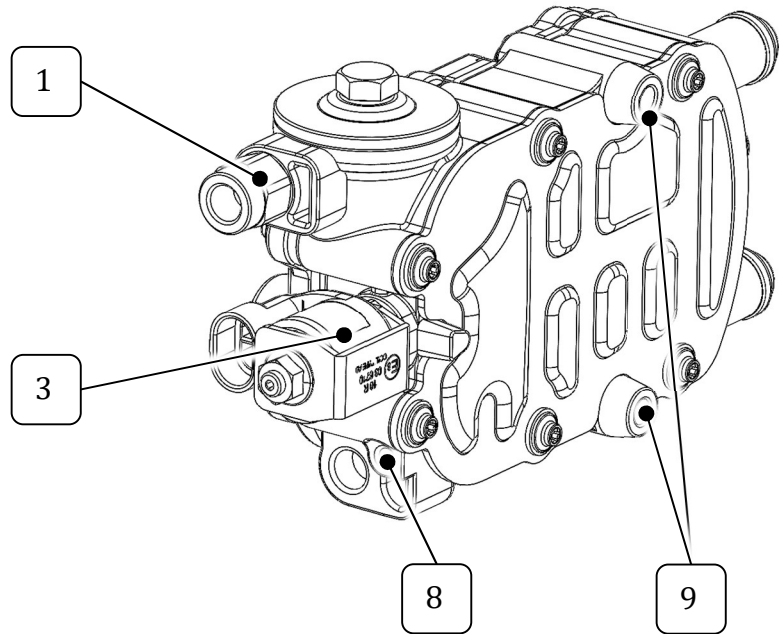

1. LPG inlet joint M10x1 (pipe Ø6)
2. Liquid phase filter
3. Solenoid valve
4. Gas outlet joint Ø12
5. MAP joint Ø6
6. Heating circuit joint Ø16 (x2)
7. Adjust-pressure screw
8. Seat for temperature sensor M5
9. Frame fixing point

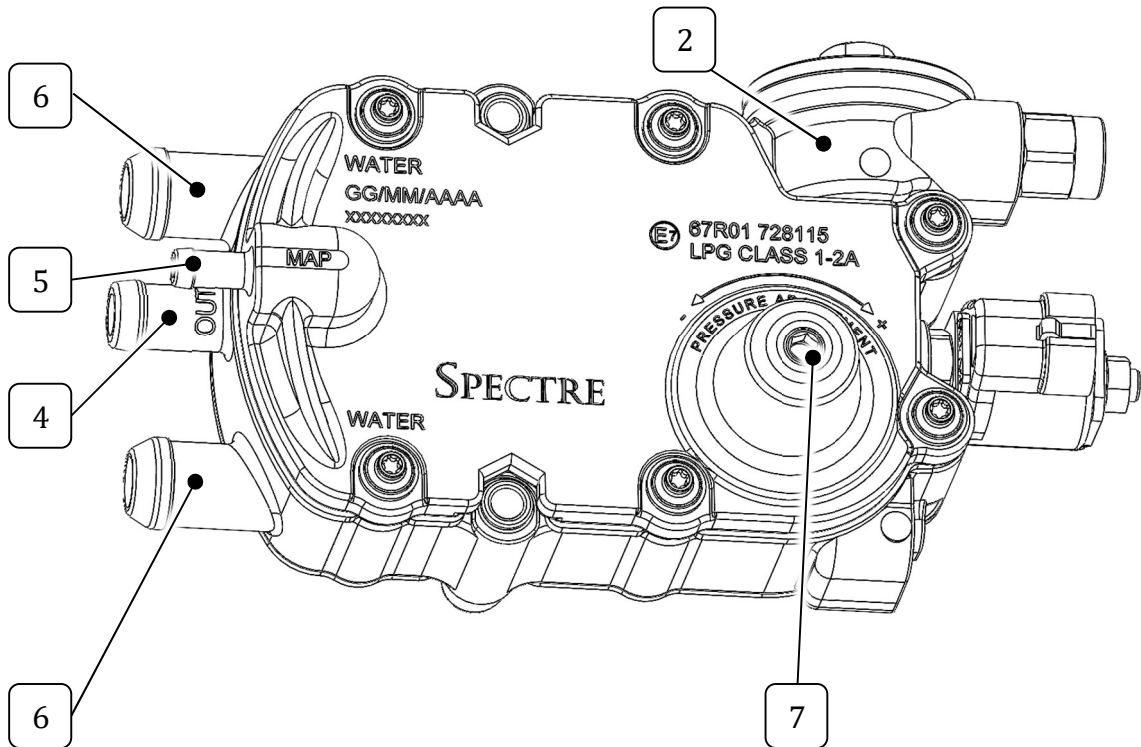

4. INSTALLATION GUIDELINES

4.1 GENERAL RECOMMENDATIONS

- Install the reducer below the level of the radiator expansion tank to avoid air bubbles in the coolant circuit and ensure proper heating.
- Avoid mounting the unit near high-temperature components such as the exhaust system. Maintain a minimum distance of 150 mm from heat sources. If this isn't possible, a heat shield at least 1 mm thick must be installed. Even with shielding, never go below 75 mm.
- The order of height between components should be: regulator at the lowest point, then gas filter, and injector rail at the highest point, to prevent impurities from reaching the injectors.
- Use only the frame fixing points indicated above.
- Do not install the regulator with the gas outlet facing downward.
- Keep the device away from areas subject to strong vibrations. Never mount it directly on the engine block.
- Choose an installation point that allows easy access to the pressure adjustment screw and the liquid phase filter, facilitating future maintenance.
- Ensure the installation does not interfere with other engine components or moving parts.
- Use a regulator model appropriate for the engine's power, with an adequate reserve margin.
- The recommended working pressure is 1.20 bar.
- The use of a M12x1 inlet joint (for a Ø8 mm hose) is required for:
 - Turbocharged engines above 100 kW
 - Naturally aspirated engines above 120 kW

This fitting is available as a KIT.

For the above-mentioned engines, set the reducer working pressure to 1.40 bar.

- After a few thousand kilometers, it is advisable to:
 - Check and possibly readjust gas pressure.
 - Verify that there are no leaks in the coolant circuit.

4.2 INSTALLATION PROCEDURE

Mounting the Regulator

- Secure the regulator to the vehicle chassis or body using the bracket and screws provided. The unit should be mounted in a protected area of the engine bay, away from potential impact zones and easily accessible.

- Bracket
- M6x55 S.H.C.S. (x2)
- M6 nut (x2)
- Grower washer (x2)

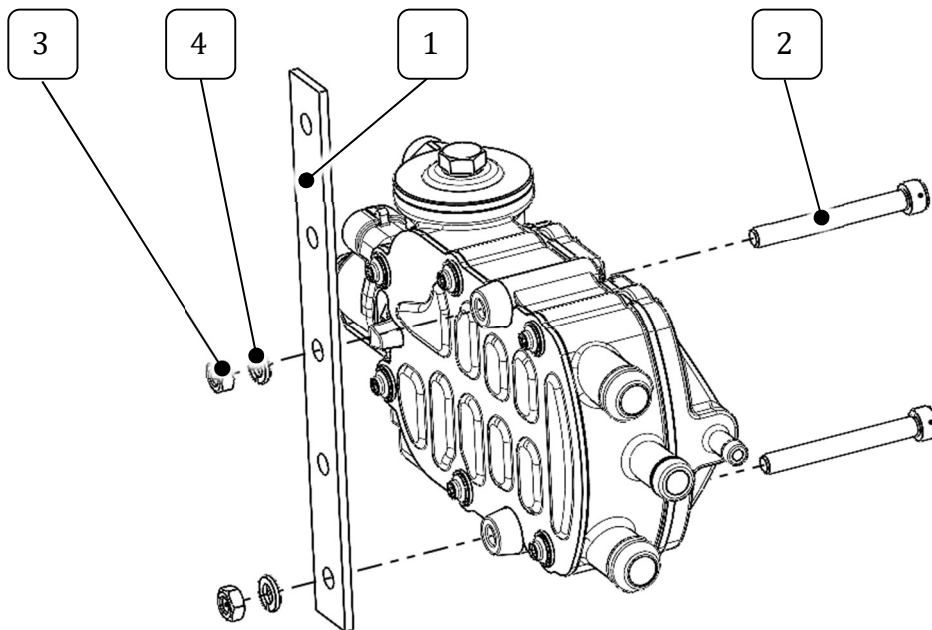

- WARNING:** It is forbidden to install the reducer with the bracket on the opposite side of the reducer.

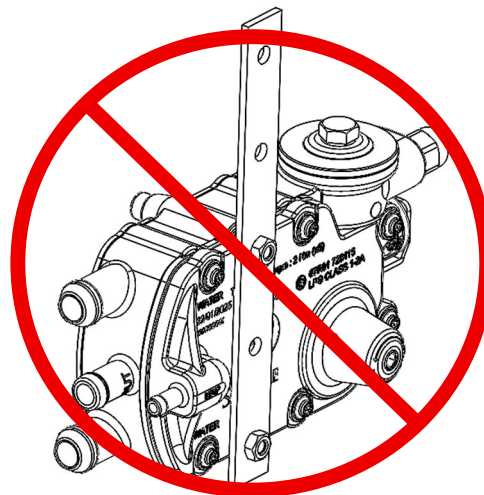

- **WARNING:** It is forbidden to install the reducer with the gas output facing upwards (gas input facing downwards)

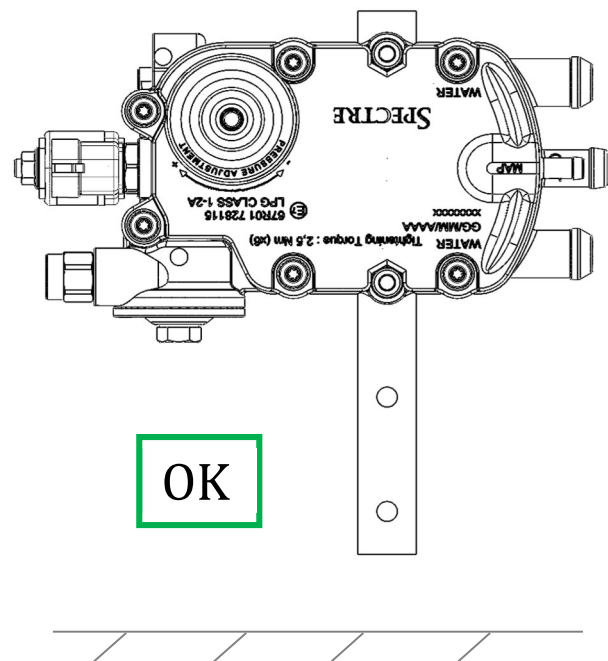
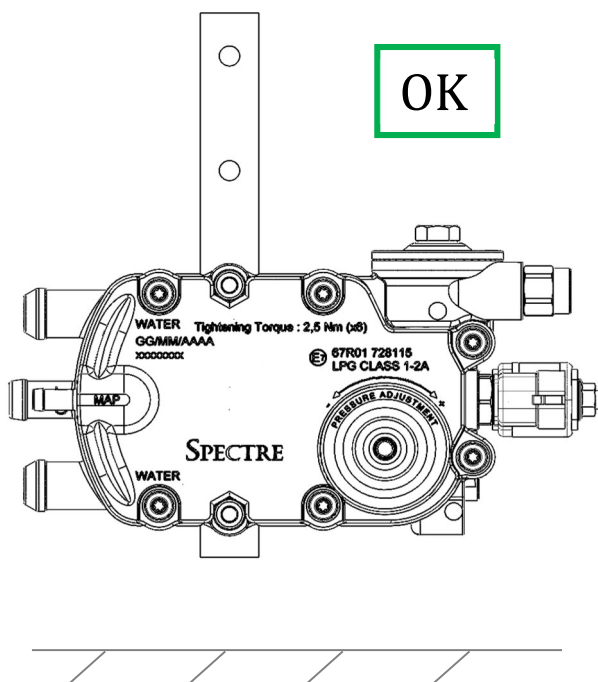
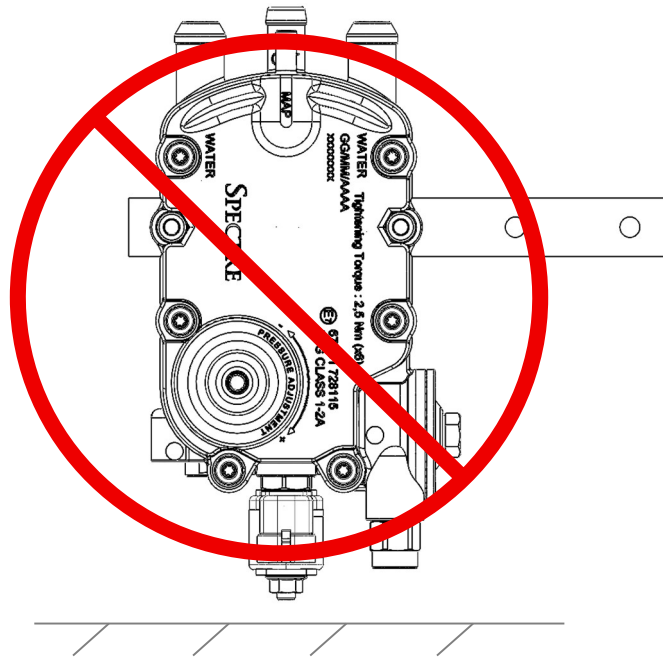

Gas Supply and Outlet

- Connect the liquid phase gas inlet using the kit provided with the reducer:

1. Double cone ferrule $\varnothing 6$
2. Cone-tightening screw M10x1

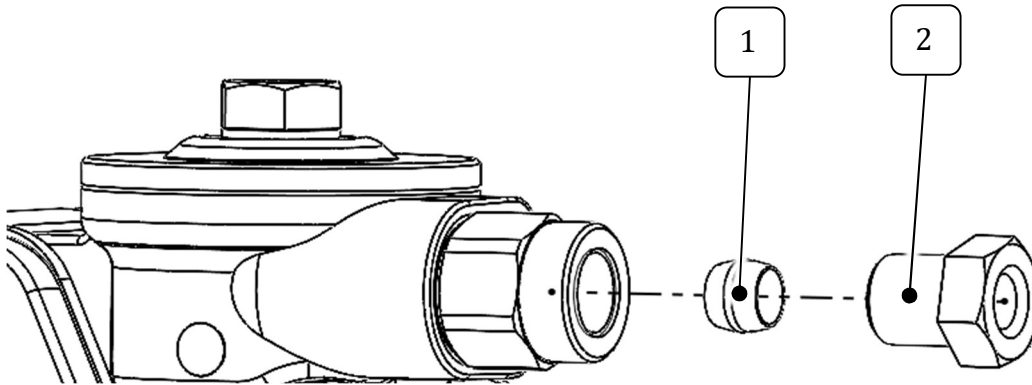

- The vapor phase gas outlet is designed for a 12 mm internal diameter rubber hose.
- Secure all hose connections with proper clamps to prevent leakage
- If the $\varnothing 8$ mm pipe connection KIT is included, connect the liquid phase gas inlet using the kit provided with the reducer:

1. O-Ring 9.25x1.78
2. M12x1 Joint
3. Double cone ferrule $\varnothing 8$
4. Cone-tightening screw M12x1

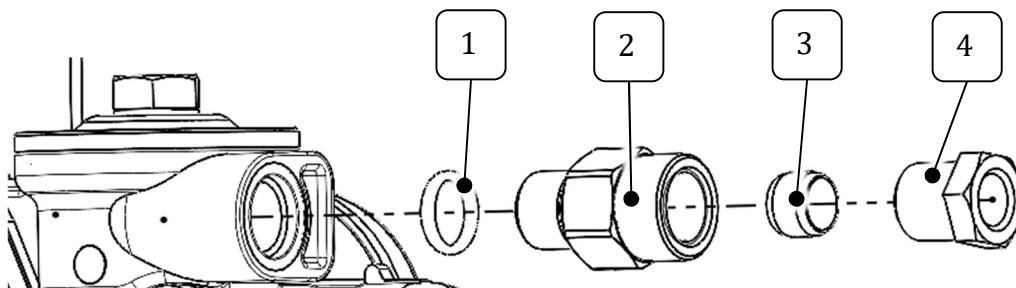

Connecting the Heating Lines

- Connect the heating inlet and outlet using rubber hoses with an internal diameter of 16 mm. It is recommended to connect the circuit in parallel, as a series connection is not advisable.

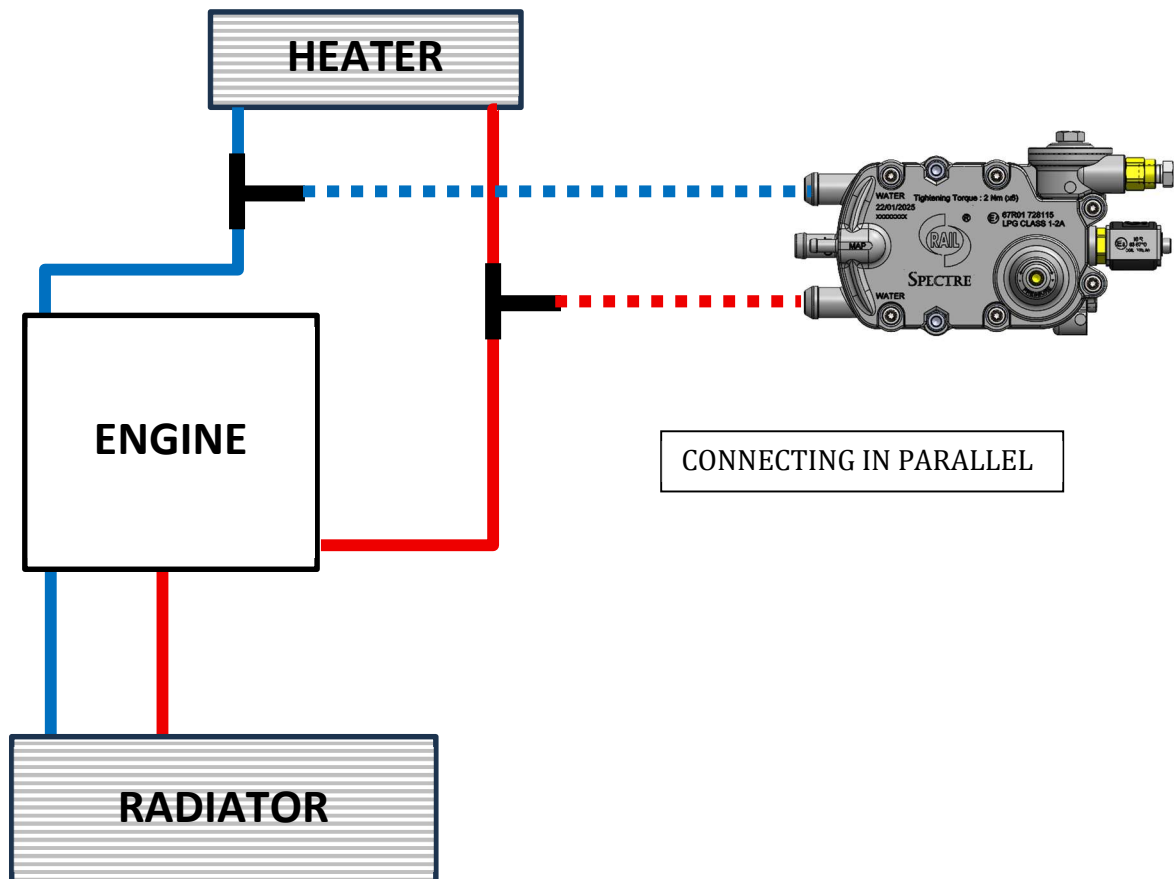

- Use either sized “T” joints or “linear” joints
- Secure all hose connections with proper clamps to prevent leakage.
- After installation, bleed the cooling system to eliminate air pockets and top up the coolant to the proper level.
- The orientation of the coolant flow in the regulator is not direction-sensitive.

Connecting the MAP Line

- Connect the MAP connection pipe to the engine intake manifold, to allow pressure compensation
- Secure all hose connections with proper clamps to prevent leakage.

Additional Connections

- If the temperature sensor is provided, install it in the dedicated port on the regulator body.

Solenoid valve

- Connect the solenoid valve. Do not change the angular position of the coil to avoid loosening the flanged nut.

Final Checks

- Ensure no kinks or sharp bends are present in any hose, especially in low-pressure gas lines.
- Confirm all connections (gas, coolant, and MAP) are tight and leak-free.
- Start the engine and verify that:
 - No gas or coolant leaks are present.

Pressure Adjustment

- Adjust the outlet pressure by turning the 5 mm Hex screw:
 - Turn clockwise (+) to increase pressure.
 - Turn counterclockwise (-) to decrease pressure.
 - Once the adjustment screw reaches its mechanical limit, do not force it further to avoid damaging the internal components
 - Total range: 7 turns

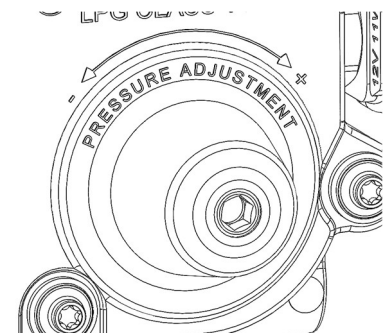

5. MAINTENANCE

- Every 20,000 km: Check / Adjust outlet pressure
- Every 20,000 km or 1 year: Replace filter cartridge (See *Appendix B* for Replacement KIT and instructions)
- As needed: Complete reducer overhaul, including EV replacement (See *Appendix C* for Replacement KIT and instructions) and membrane replacement (See *Appendix D* for Replacement KIT and instructions)
- Always check for leaks and component wear
- In case of heavy dirt or contamination, perform a complete overhaul more frequently.
- The injector rail filter must be serviced or replaced regularly to prevent fluctuations in the reducer's outlet pressure

6. SAFETY WARNINGS

- Do not tamper with sealed components
- Never perform maintenance with the engine running
- Do not use high-pressure water on reducer or electrical parts
- Ensure only certified personnel perform installations
- Keep away from the vehicle with any open flames (e.g., cigarettes) or spark-generating devices

7. WARRANTY CONDITIONS

See *MOD.CQ.024 / WARRANTY CONDITIONS*

Disclaimer: Ecomotive Solutions reserves the right to make changes to this manual and the warranty conditions without prior notice, unless required for safety reasons or to ensure the proper functioning of the reducer.

8. APPENDICES

A. Torque Specifications

- Mounting bracket bolts: 9 Nm ±15%
- Filter screw: 12 Nm ±15%
- Inlet Fitting: 8 Nm ±15%
- EV Plunger housing: 8 Nm ±15%
- EV coil nut: 2.5 ÷ 3 Nm
- Lever screw: 3.8 Nm ±15%
- Gas cover bolts: 2.5 Nm MAX when assembling new screws after seal replacement
- Gas cover bolts: 4.5 Nm MAX when tightening a loose screw
- Water cover bolts: 2.5 Nm MAX when assembling new screws after seal replacement
- Water cover bolts: 4.5 Nm MAX when tightening a loose screw

B. Filter replacement

To replace the filter, use the SPECTRE / SPECTRE II FILTER REPLACEMENT KIT which includes:

- n.1 cartridge filter (5)
- n.1 O-Ring 34.60x2.62 (4)
- n.1 O-Ring 26.70x1.78 (6)
- n.1 Bonded seal washer (2)

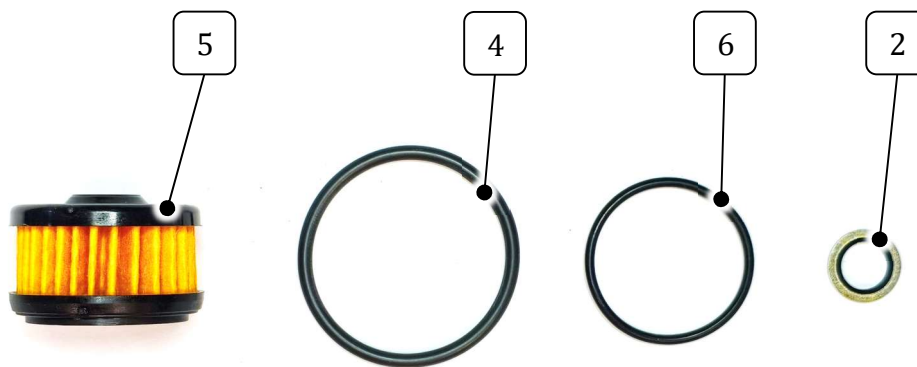

Replacement instructions:

1. Unscrew the bolt (1) with its bonded seal washer (2)
2. Remove the cover (3) and the upper O-Ring 34.60x2.62 (4)
3. Remove the filter (5) and the lower O-Ring 26.70x1.78 (6)
4. Clean the area / body
5. Replace the O-Rings (4,6) and put them in the correct position
6. Replace the filter (5)
7. Close the area with cover (3) and tight the bolt (1) + new bonded seal washer (2)

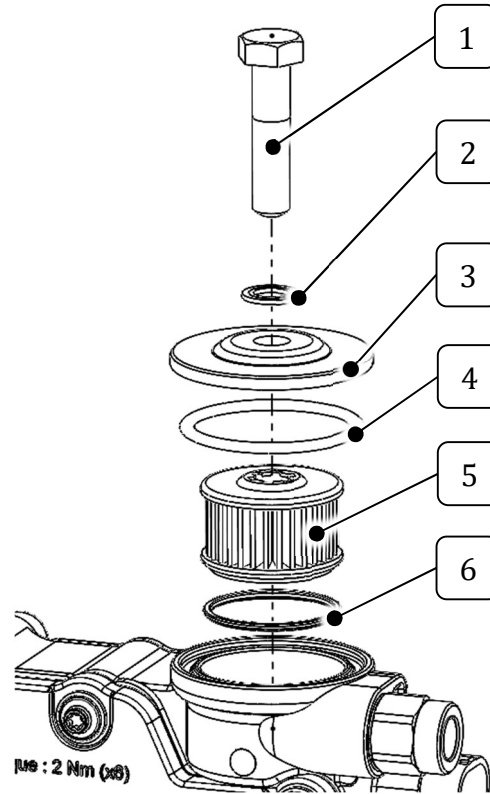

C. Solenoid valve replacement

To replace the solenoid valve components, use the SPECTRE / SPECTRE II SOLENOID VALVE REPLACEMENT KIT which includes:

- n.1 Mobile plunger and Piloted plunger assembly (5)
- n.1 O-Ring 12.42x1.78 (4)

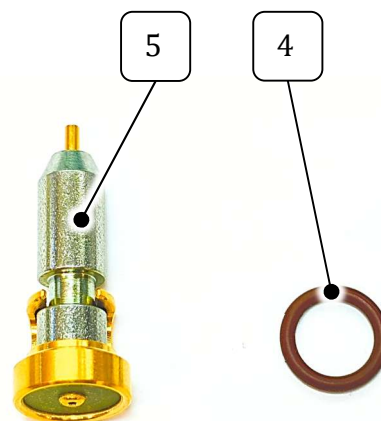

Replacement instructions:

1. Unscrew the hex nut (1)
2. Remove the coil (2) and armature (6)
3. Unscrew the fixed plunger assembly (3) and replace the 12.42x1.78 O-Ring (4) mounted on the fixed plunger assembly (3)
4. Replace the Mobile plunger and Piloted plunger assembly (5) and put it in its seat in the aluminum body
5. Tight the fixed plunger assembly (3)
6. Insert the coil (2) in the armature (6) and assembly them on the fixed plunger assembly (3)
7. Tight the hexagon nut (1)

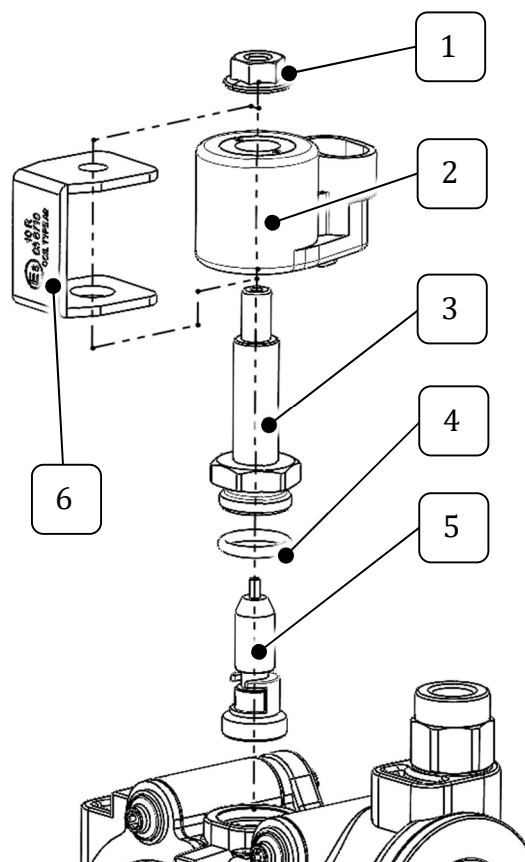

D. Membrane and water circuit seal replacement

To replace the membrane and the water circuit seal, use the SPECTRE SEALS REPLACEMENT KIT which includes:

- n.1 Membrane assembly (5)
- n.1 Lever assembly (6)
- n.6+6 Cover screws (1;9)
- n.1 7.66x1.78 O-ring (3)
- n.1 Heating circuit seal (11)

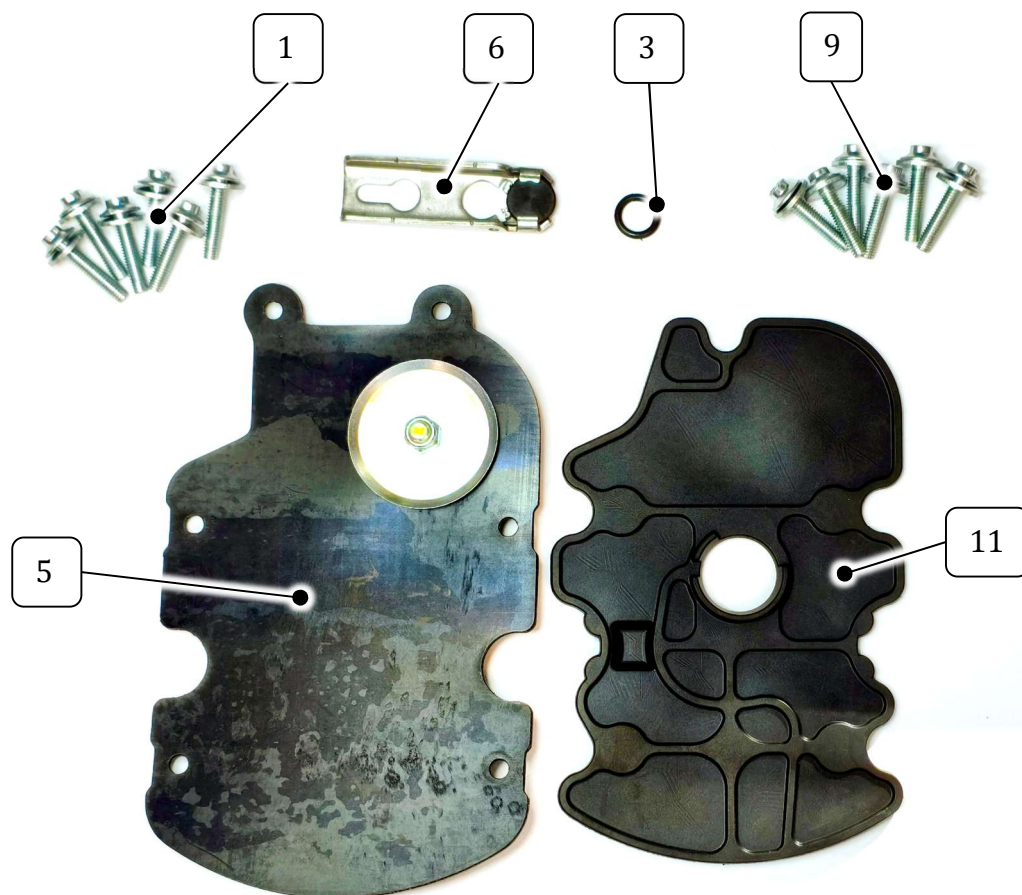

Replacement instructions:

1. Unscrew the six screws (1) on the gas cover (2). To counteract the spring force, it is advisable to use a clamp to secure the reducer during disassembly.
2. Remove the cover (2).
3. Replace the 7.66x1.78 O-ring on the spring pressure adjuster (4).
4. Remove the diaphragm (5) from the reducer body and replace it with the new one
5. Unscrew the lever bolt (7).
6. Remove the lever pin (8) and replace the lever assembly (6).

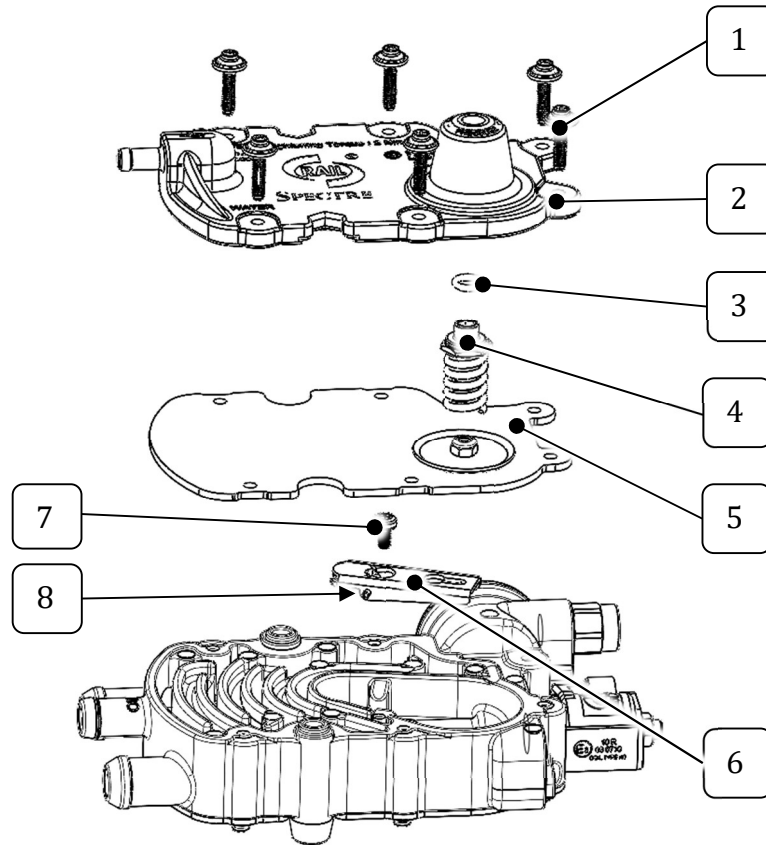

7. Insert the pin (8) into the new lever assembly (6).
8. Place the lever assembly in its seat and tighten the bolt (7).
9. Insert the new diaphragm assembly into its seat, ensuring the pin is correctly positioned in the lever.

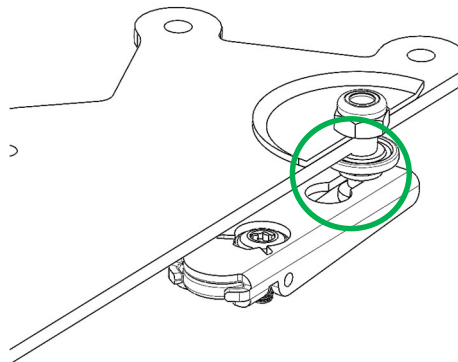

10. Position the spring and pressure adjustment assembly.
11. Place the cover (2) in position and ensure correct alignment between the reducer body, diaphragm (5), and cover (2).
12. Once alignment is achieved, insert and tighten the new cover screws (1). The old screws must be discarded.

13. After tightening all the screws, go over them a second time to ensure they are properly tightened.
14. To replace the heating liquid seal, it is necessary to unscrew the n.6 screw on the water side (9), then remove the cover (10), replace the seal (11).
15. Put the cover (10) in the correct position and tighten the new cover screws (9). The old screws must be discarded.
16. After tightening all the screws, go over them a second time to ensure they are properly tightened.

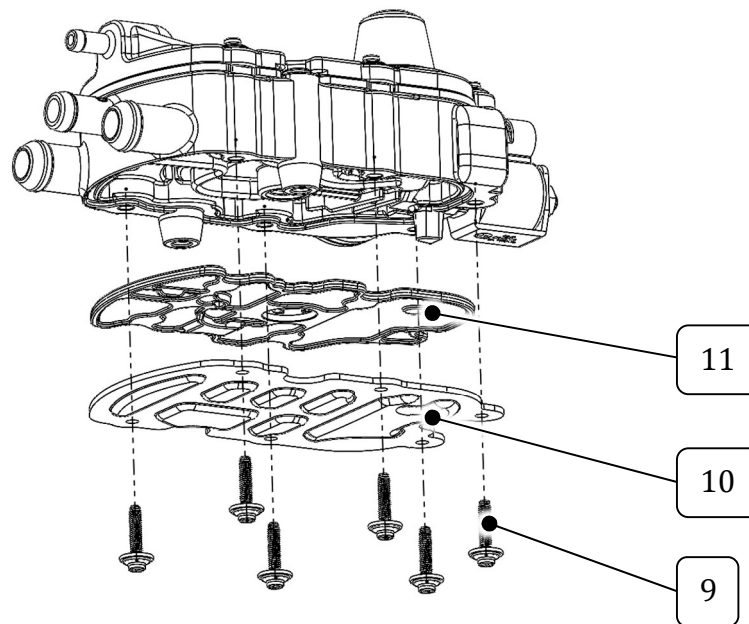

E. Outlet / MAP configurations

1. N.1 Spectre reducer / In-line Engine

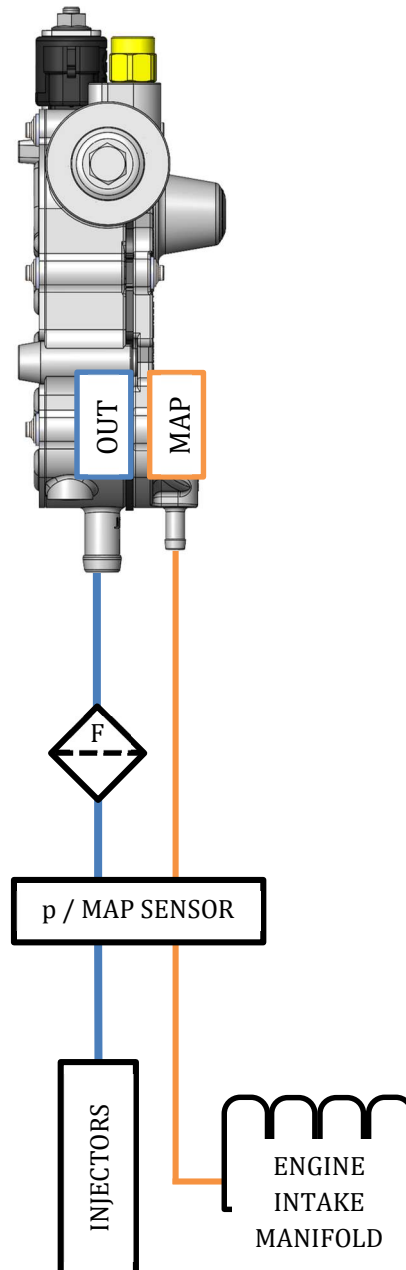

2. N.2 Spectre reducers / "V" Engine

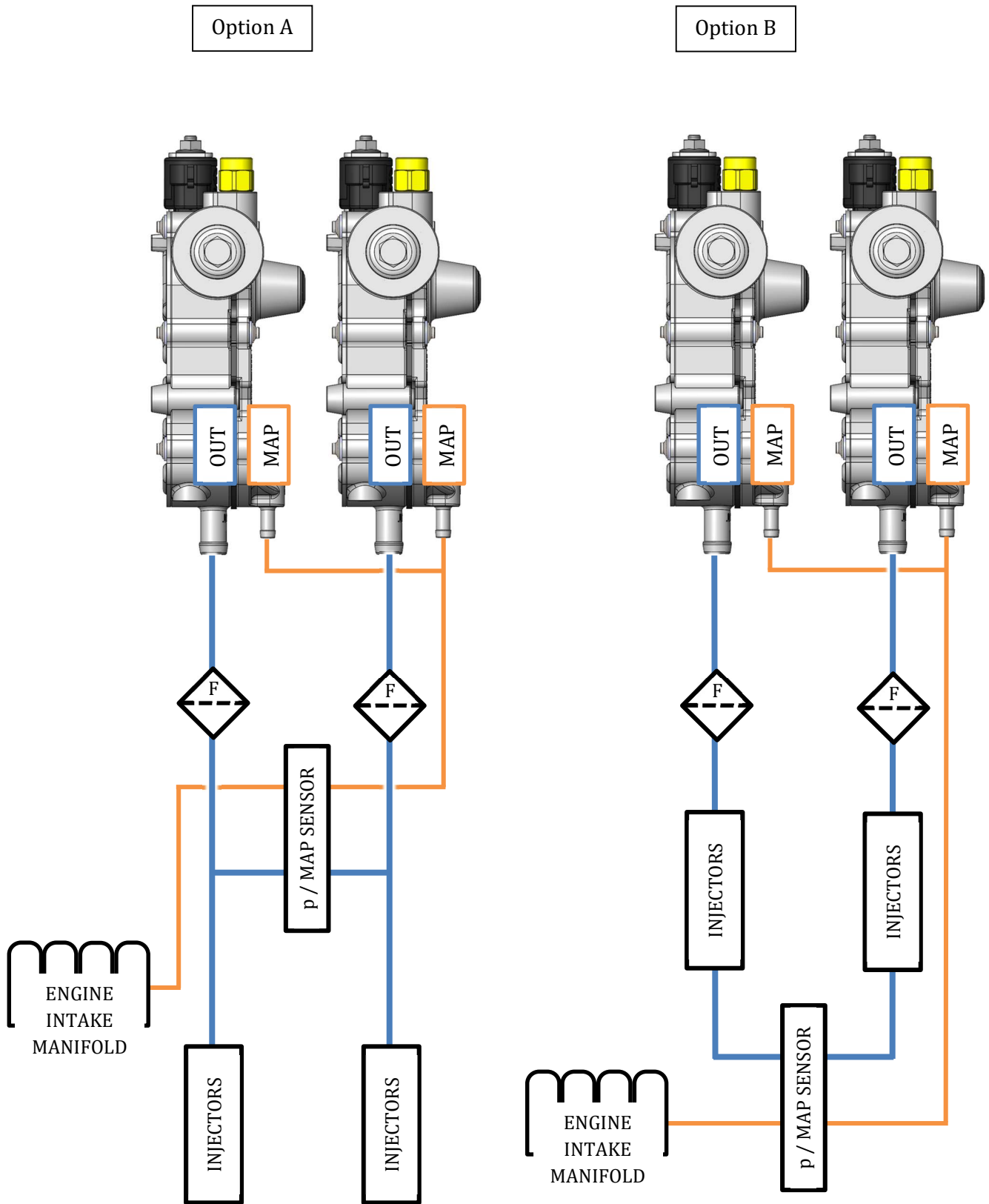

Option C

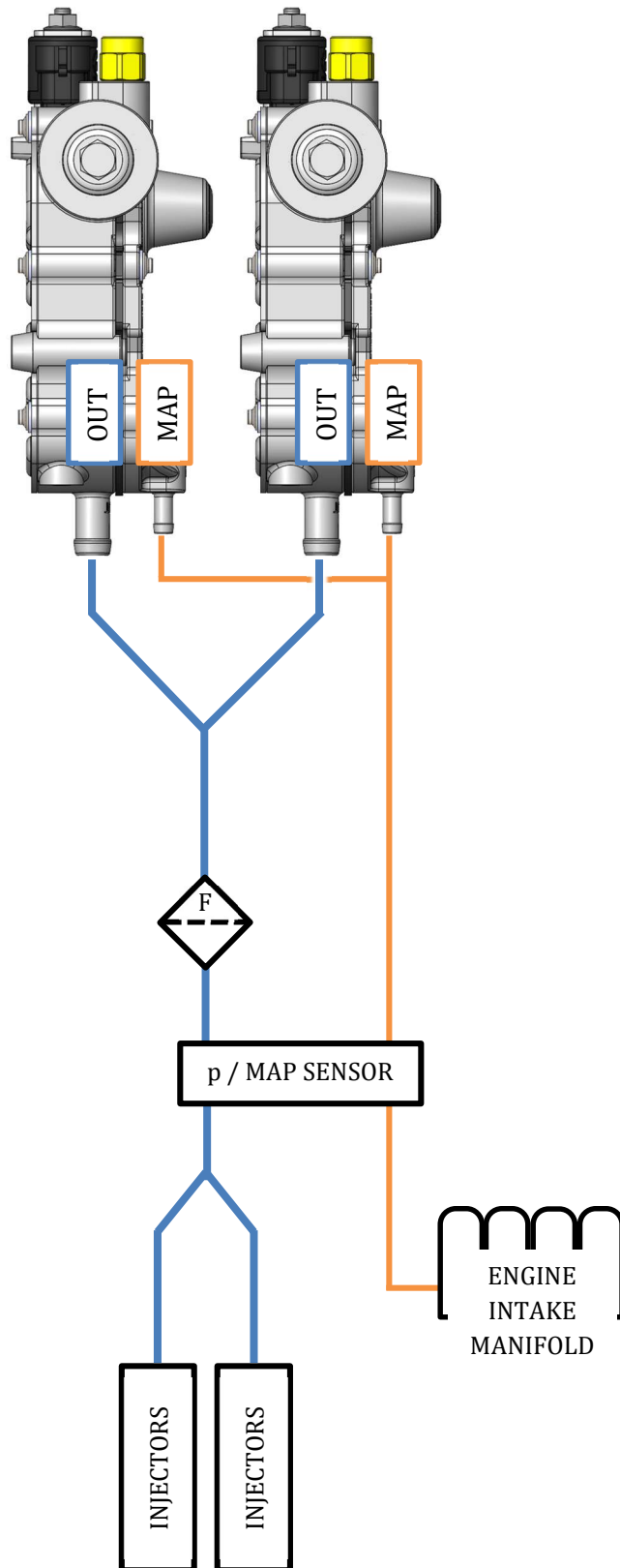



ECOMOTIVE SOLUTIONS S.R.L.

Local Unit of: Via A. Grandi, 16 42030

Vezzano Sul Crostolo (RE) – Italy

Tel.: +39 0522 603801

Email: info@railgroup.it